

**WOODFOLD**  
**ACCORDION DOORS**

For Commercial and Residential Installations

*Since 1957*

**2012**

Effective 1-1-12

WOODFOLD ACCORDION DOOR GUIDE ■ Detailed Architectural Shop Drawings Available.

**Code Explanations**

Furnished as Standard: **STD**  
 Optional: **OPT**  
 Not Available: —

	Series 140	Series 220	Series 240	Series 440	Series 540	Series 640	Series 740	Series 2100	Series 3300
Continuous Pin Hinge Hardware System, Top & Bottom	STD	STD	STD	STD	STD	STD	STD	STD	STD
Full-length Sweptwing Handle With Magnet	STD	STD	—	—	—	—	—	—	—
Aluminum Lead Post	—	—	STD	STD	STD	STD	STD	STD	STD
Flexible Vinyl Panel Connector Inserted Directly Into Panels	STD	STD	STD	—	—	—	—	STD	STD
Flexible Vinyl Panel Connector Inserted Into Aluminum Side Channel	—	—	—	STD	—	—	—	—	—
Flexible Vinyl Panel Connector Inserted Into Solid Aluminum Panels	—	—	—	—	—	STD	—	—	—
Rigid Vinyl Panel Connector Inserted Into Aluminum Side Channel	—	—	—	—	STD	—	—	—	—
Rigid Vinyl Panel Connector Inserted Into Solid Aluminum Panels	—	—	—	—	—	—	STD	—	—
Nylon Wheel on Lexan Axle	STD	STD	—	—	—	—	—	—	—
Nylon Wheel with Ball Bearings on Steel Axle	OPT	OPT	STD	STD	STD	STD	STD	STD	STD
Aluminum Track	STD	STD	STD	STD	STD	STD	STD	STD	STD
Recessed Track Channel	OPT	OPT	OPT	OPT	OPT	OPT	OPT	—	OPT
Curvable Track	—	—	OPT	OPT	OPT	OPT	OPT	—	—
Magnetic Catch & Strike Plate	STD	STD	OPT	OPT	OPT	OPT	OPT	OPT	OPT
Deadlatch with Thumb Turn Two Sides	—	—	STD	STD	OPT	STD	OPT	STD	STD
Keylock Two Side	—	—	OPT	OPT	STD	OPT	STD	OPT	OPT
May Be Paired	—	—	OPT	OPT	OPT	OPT	OPT	OPT	OPT
Sliding Jamb Option	—	—	OPT	OPT	OPT	OPT	OPT	OPT	OPT
Class 1 Fire Retardant Panels (Light Oak & Chalk Vinyl-Lam Only)	—	OPT	OPT	OPT	OPT	—	—	OPT	OPT

**Measuring Width & Height**

List finished opening sizes.

(A) Width: Finished wall to wall (or jamb) in feet and inches; e.g. 10-5 x 7-10.

(B) Height: From surface where track attaches to finished floor or top of carpet.

**See Page 4.**  
**Drawings show how to measure height for each type of track.**

NOTE: For those areas where floor is uneven (e.g. concrete floors) please take 3 or 4 height measurements along the floor. Use the shortest measurement as the finished opening height except 2100 and 3300.

**Woodfold order forms available.**

*All Woodfold finishing processes are environmentally safe.*

**CUSTOM SIZES OUR SPECIALTY**

**PREPAID FREIGHT PROGRAM**

All prices shown in this price list include freight for Zone 2

**Production Schedule:**

All Series with factory standard finishes, 2 weeks (up to 250 lineal feet; over 250 lineal feet – subject to manufacturers schedule at time of order.) All doors with special finish; after signed approved acknowledgement received, 3 weeks.

**Rush Service:** Please contact office for details.

**In-transit Time:**

Please allow a 7 to 10 day normal in-transit time for delivery.

**Door weights (lbs per lineal foot)**

Height	140, 220, 240 & 2100		440, 540, 640 & 740		3300
	240 & 2100	140, 220, 240	640 & 740	440, 540	
6-8	10				
8-0	12		13		26
10-0	15		16		32
12-0	18		20		38

**FREIGHT ZONE 2**  
 Includes all continental states except California, Oregon, Washington

**CUSTOM ORDER INFORMATION**

**Custom Sizes:** All Woodfold doors are custom made. We allow 9/16" clearance for doors over 4' high, 5/16" for doors 4' high and less.

*Due to variations in floor and/or ceiling surfaces we suggest several height measurements be taken across door opening.*

**Special finishes procedure:** With your order please send stained wood sample or paint chip to be matched by Woodfold. Upon receiving this sample we will return a factory color-matched sample along with an acknowledgement copy. Acknowledgement is to be returned with your signature approving the color match. By using the special finish procedure to color match to your customer requirements, the special finish cost will be less than preparing an unfinished door for finishing at the job site.

**Unfinished Doors are not guaranteed.**  
**(Series 3300 is not available unfinished)**

**Shipments to commercial addresses.**  
**Additional charges apply for non-commercial delivery and pre-delivery notification.**  
**Contact Office for Questions.**

**SPECIAL NOTE:** In case of freight damage documented with signed bill of lading, please contact our office. Woodfold will process freight claim.

# RESIDENTIAL Series 140

CLOSET FOLDING DOORS—FACED ONE SIDE ONLY

**\*\* FREIGHT \*\***  
**\*\* PREPAID \*\***

Order must specify left or right hand stack.

Not available as pairs.

When pairs are required, use Series 240.

## SERIES 140 SPECIFICATIONS

**Panels:** 4-1/4" wide.

**Factory Finished Hardwoods:** For visual warmth, hardwood veneers laminated to MDF board (1/4" net) with *non-tinted* finish. Good one side.

**Vinyl-Lam:** Wood grains, white, tan, gray or 2-tone textured vinyl laminated to 1/4" MDF board, faced one side only (plant option to have a utility-grade back).

**Catch:** Magnet with strike plate.

**Widths:** Up to 8'.

**Heights:** Up to 8'1".

**NOTE:** For closet enclosures more than 8' wide use Series 240 with closet-back option, Page 5.

**Wheels:** Nylon wheels on Lexan axles.

**Vinyl Panel Connectors:** Supplied as standard – **White** with White, Chalk, and Amethyst.

**Sand** with Hardwoods: Oak, Birch, Maple; and  
Vinyls: Natural Oak, Birch, Tan, Tahiti, Rattan, Maple.

**Gray** with Gray Vinyl.

**Brown** with all other body panels.

**Stacking Space:** 1-1/4" per foot plus 7/8" for sweptwing handle.

**NOTE:** Not available with curved track.

THE ACCORDION DOOR THAT:

- Is Fully Guaranteed
- STACKS in Minimum SPACE
- STAYS PUT in Open and Closed Position
- Has Exclusive Pin-Hinge Hardware Top and Bottom for Added Strength

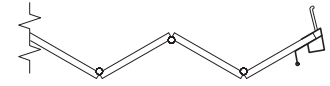

Left Stack

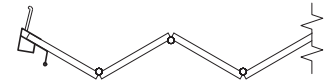

Right Stack



## LIST PRICE SCHEDULE

Use for Custom and Stock Sizes	Series 140V Vinyl-Lam	Series 140H Natural Hardwoods				
		Factory Finished				
FINISHED OPENINGS UP TO	Cherry, Maple, Gray, Birch, Natural Oak, Light Oak, Dark Oak, Teak, Mahogany, Walnut, White, Tan, Chalk, Tahiti, Rattan, Amethyst	BIRCH	OAK	CHERRY WALNUT	MAHOGANY MAPLE	
WIDTH X HEIGHT						
Heights up to 6' 10" NO EXTRA CHARGE	2-0 x 6-8	218	374	380	498	442
	2-6 x 6-8	327	561	570	747	663
	2-8 x 6-8	327	561	570	747	663
	3-0 x 6-8	327	561	570	747	663
	3-6 x 6-8	436	748	760	996	884
	4-0 x 6-8	436	748	760	996	884
	5-0 x 6-8	545	935	950	1245	1105
	6-0 x 6-8	654	1122	1140	1494	1326
Heights up to 8' 1" NO EXTRA CHARGE	7-0 x 6-8	763	1309	1330	1743	1547
	8-0 x 6-8	872	1496	1520	1992	1768
	2-6 x 8-0	369	627	636	825	735
	3-0 x 8-0	369	627	636	825	735
	4-0 x 8-0	492	836	848	1100	980
	5-0 x 8-0	615	1045	1060	1375	1225
	6-0 x 8-0	738	1254	1272	1650	1470
	7-0 x 8-0	861	1463	1484	1925	1715
8-0 x 8-0	984	1672	1696	2200	1960	

Maximum size for Series 140: 8-0 x 8-0

### PRICE TO NEXT FULL FOOT WIDTH AND HEIGHT

Series 140 with full length swept wing handle with integral magnet and steel hardware hinge. (Top View)

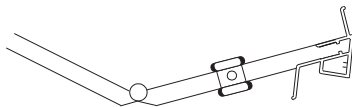

NOTE: The first body panel acts as lead panel.

## SERIES 140 OPTIONS

- CUSTOM-SIZE DOORS  
No additional charge  
(Use price for next larger width and height shown); see Page 1 for providing custom-size details.
- HEIGHTS 4' AND LESS . . . . . less 20%  
Use 8-0 height price.
- DOUBLE END – single door with sweptwing handle both ends . . . . . \$20
- Not available with keylocks or privacy latches (for these options, use series 240 with closet back).
- SPECIAL PAINT & STAIN . . \$40 LIN.FT.  
NOTE: For custom paint finish, use (\$100 min.) wood-grain vinyl base price (MDF board, used for paint finish).  
For stain finish use wood-species base price. See front cover for details.
- FIRE-RETARDANCY . . . . . N/A  
Panels with fire-retardant core not available in Series 140. Please refer to options for Series 220 and 240.

# RESIDENTIAL Series 220

## ROOM DIVIDERS AND PASSAGEWAY DOORS

**\*\* FREIGHT \*\***  
**\*\* PREPAID \*\***

Not available as pairs.  
When pairs are required, use Series 240.  
Built left hand stack unless otherwise specified.

### CUSTOM SIZES OUR SPECIALTY

#### HOW TO ORDER

- 1) **WIDTH:** Finished wall to wall (or jamb) in feet and inches.
- 2) **HEIGHT:** Surface where track attaches to finished floor or top of carpet in feet and inches.
- 3) **SERIES:** List number of the series to be ordered.
- 4) **PANEL:** List wood species or vinyl-lam color.
- 5) **OPTIONS:** List options if required.

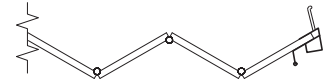

Left Stack

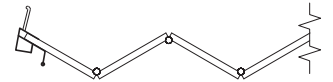

Right Stack



### SERIES 220 SPECIFICATIONS

**Panels:** 4-1/4" wide.

**Factory Finished Hardwoods:** For visual warmth, hardwood veneers laminated to MDF board (1/4" net) with *non-tinted* finish.

**Vinyl-Lam:** Wood grains, white, tan, gray or 2-tone textured vinyl laminated to 1/4" MDF board.

**Catch:** Magnet with strike plate.

**Widths:** Up to 8'.

**Heights:** Up to 8'1".

**NOTE:** For room dividers more than 8' wide use Series 240, Page 5.

**Wheels:** Nylon wheels on Lexan axles.

**Vinyl Panel Connectors:** Supplied as standard – **White** with White, Chalk, and Amethyst.

**Sand** with Hardwoods: Oak, Birch, Maple; and  
Vinyls: Natural Oak, Birch, Tan, Tahiti, Rattan, Maple.

**Gray** with Gray Vinyl.

**Brown** with all other body panels.

**Stacking Space:** 1-1/4" per foot plus 7/8" for sweptwing handle.

**NOTE:** Not available with curved track.

### LIST PRICE SCHEDULE

Use for Custom and Stock Sizes	Series 220V Vinyl-Lam	Series 220H Natural Hardwoods				
		Factory Finished				
FINISHED OPENINGS UP TO	Cherry, Maple, Gray, Birch, Natural Oak, Light Oak, Dark Oak, Teak, Mahogany, Walnut, White, Tan, Chalk, Tahiti, Rattan, Amethyst	BIRCH	OAK	CHERRY WALNUT	MAHOGANY MAPLE	
WIDTH X HEIGHT						
Heights up to 6' 10" NO EXTRA CHARGE	2-0 x 6-8	228	384	390	508	452
	2-6 x 6-8	342	576	585	762	678
	2-8 x 6-8	342	576	585	762	678
	3-0 x 6-8	342	576	585	762	678
	3-6 x 6-8	456	768	780	1016	904
	4-0 x 6-8	456	768	780	1016	904
	5-0 x 6-8	570	960	975	1270	1130
	6-0 x 6-8	684	1152	1170	1524	1356
Heights up to 8' 1" NO EXTRA CHARGE	7-0 x 6-8	798	1344	1365	1778	1582
	8-0 x 6-8	912	1536	1560	2032	1808
	2-6 x 8-0	384	642	651	840	750
	3-0 x 8-0	384	642	651	840	750
	4-0 x 8-0	512	856	868	1120	1000
	5-0 x 8-0	640	1070	1085	1400	1250
	6-0 x 8-0	768	1284	1302	1680	1500
	7-0 x 8-0	896	1498	1519	1960	1750
8-0 x 8-0	1024	1712	1736	2240	2000	

Maximum size for Series 220: 8-0 x 8-0

#### PRICE TO NEXT FULL FOOT WIDTH AND HEIGHT

Series 220 with full length swept wing handle with integral magnet and steel hardware hinge. (Top View)

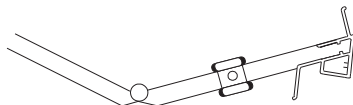

NOTE: The first body panel acts as lead panel.

### SERIES 220 OPTIONS

- **CUSTOM-SIZE DOORS**  
No additional charge  
(Use price for next larger width and height shown); see Page 1 for providing custom-size details.
- **HEIGHTS 4' AND LESS . . . . .** less 20%  
Use 8-0 height price.
- **DOUBLE END** – single door with sweptwing handle both ends . . . . . \$20
- **Not available with keylocks or privacy latches (for these options use Series 240).**
- **SPECIAL PAINT & STAIN . . \$40 LIN.FT.**  
*NOTE: For custom paint finish, use wood-grain vinyl base price (MDF board, used for paint finish). For stain finish use wood species base price. See front cover for details.* (\$100 min.)
- **FIRE-RETARDANCY . . . . .** add 40%  
Panels with Class 1 fire-retardant core. Available in light oak and chalk Vinyl-Lam only.

# CONSTRUCTION DETAILS

SERIES 240, 440, 540, 640, 740

## STANDARD SURFACE TRACK

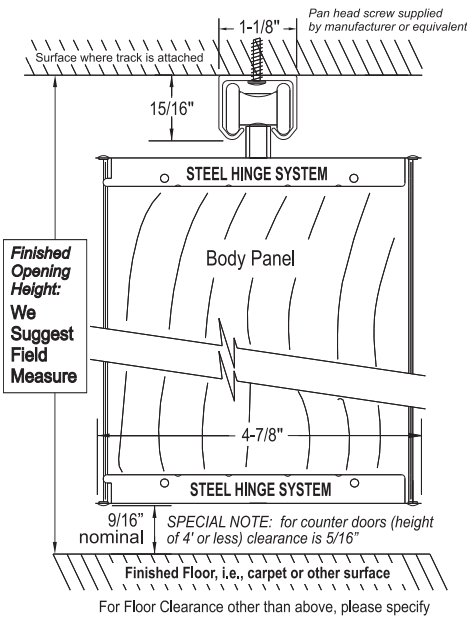

## STACK DIMENSIONS

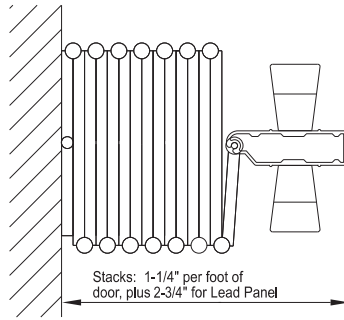

## LEAD POST

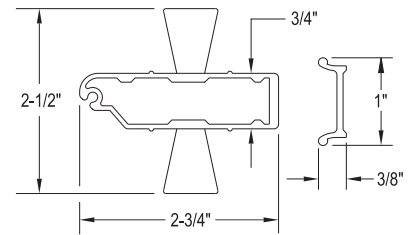

## MOUNTING PANEL

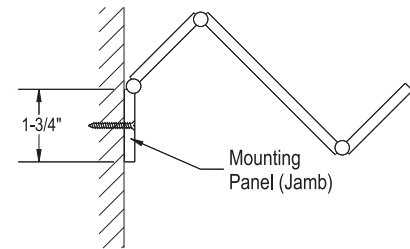

## DOOR TYPES

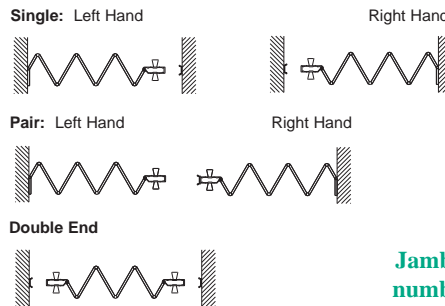

Jamb Panels may orient into or out of room based on number of panels in door. Applies to all series except 3300.

# OPTION DETAILS

SERIES 240, 440, 540, 640, 740

## LOCKING HARDWARE

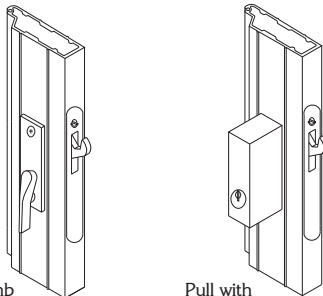

### DEADLATCH

Deadlatch with thumb turn two sides

### KEYLOCK 1 SIDE

Deadlatch with thumb turn one side, keylock one side

### KEYLOCK 2 SIDES

Deadlatch with keylock 2 sides

## CUSTOM KEYING INFORMATION

Woodfold furnishes Weiser Cylinders in Adams Rite Pulls which can be adapted to: Schlage, Lockwood, Sargent, Corbin, Russwin, Dexter, and Medeco cylinders by your local locksmith.

## INTERMEDIATE ROLLING POST

Aluminum

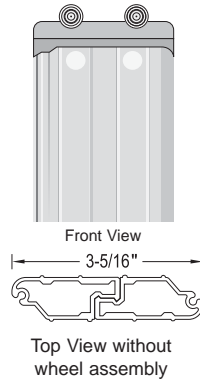

Each half of the post applied to section of Room Divider at plant. Fastening of sections at job site with screws and posts supplied.

## RECESSED TRACK

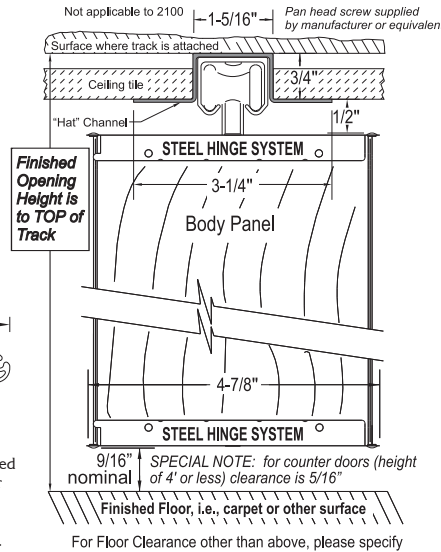

## CURVABLE TRACK

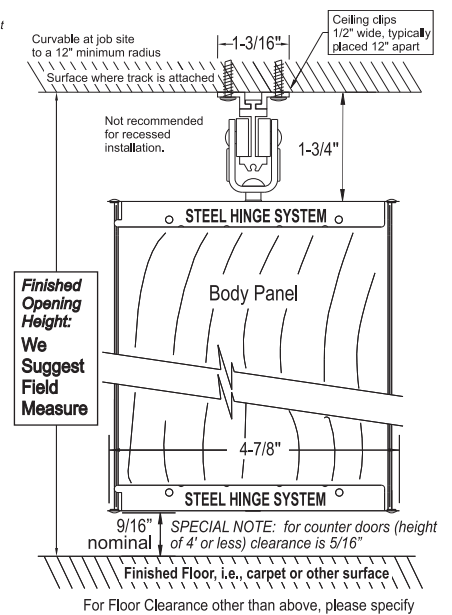

## SLIDING JAMB OPTION

POCKET DEPTH 1-1/4" per ft. of door + 7"

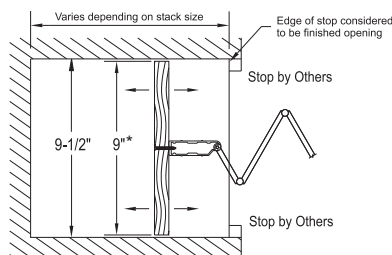

## MULTIPLE MEETING POST

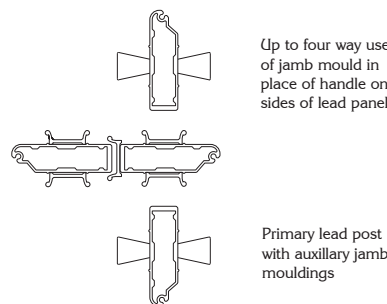

# COMMERCIAL Series 240

## ROOM DIVIDERS AND PASSAGEWAY DOORS

**\*\* FREIGHT \*\***  
**\*\* PREPAID \*\***

### CUSTOM SIZES OUR SPECIALTY HOW TO ORDER

- 1) **WIDTH:** Finished wall to wall (or jamb) in feet and inches.
- 2) **HEIGHT:** Surface where track attaches to finished floor or top of carpet in feet and inches.
- 3) **SERIES:** List number of the series to be ordered.
- 4) **PANEL:** List wood species or vinyl-lam color.
- 5) **OPTIONS:** List options if required.

### SERIES 240 SPECIFICATIONS

**Panels:** 4-1/4" wide.

**Factory Finished Hardwoods:** For visual warmth hardwood veneers laminated to MDF board (1/4" net) with *non-tinted* finish.

**Vinyl-Lam:** Wood grains, white, tan, gray or 2-tone textured vinyl laminated to MDF board (1/4" net).

**Lead post:** 3/4" x 2-3/4" Aluminum with ball bearing rollers.

**Latch:** Deadlatch with thumb turn two sides.

**Width:** No limitation.

**Heights:** Up to 12'1" on vinyl and 10'1" on hardwood.

**Vinyl Panel Connectors:** Supplied as standard – **White** with White, Chalk, and Amethyst.

**Sand** with Hardwoods: Oak, Birch, Maple; and  
Vinyls: Natural Oak, Birch, Tan, Tahiti, Rattan, Maple.

**Gray** with Gray Vinyl.

**Brown** with all other body panels.

**Wheels:** Ball bearing nylon wheels on steel axles.

**Stacking Space:** 1-1/4" per foot plus 2-3/4" for lead post.

### SERIES 240 OPTIONS

- **CUSTOM SIZES** **No additional charge**
- **HEIGHTS 4' AND LESS** . . . . . less 20%  
*Use 8-0 height price.*
- **MADE AS PAIRS** . . . . . \$40
- **DOUBLE END LEAD POST** . . . . . \$40
- **INTERMEDIATE ROLLING POST** . . . . . \$60  
*For sectioning extra wide Dividers and to provide a surface to attach foot-bolt. (See Page 4)*
- **CLOSET BACKS ON SERIES 240** . . . . . Less 10%  
*Order right or left hand /available up to 8' 1" height.*
- **UNFINISHED DOORS**  
*Not guaranteed. Use finished door prices.*
- **SPECIAL PAINT & STAIN** . . . . . \$40 LIN.FT. (\$100 min)  
*Note: For custom paint finish, use vinyl base price (MDF board used for paint finish). For stain finish use wood species base price. See front cover for details.*
- **CUSTOM DECORATIVE LAMINATE DOORS**  
*Contact office for quotation.*
- **MAGNET WITH STRIKE PLATE** . . . . . N/C
- **THUMB TURN TWO SIDES** . . . . . Std  
*Deadlatch with thumb turn two sides.*
- **THUMB TURN ONE SIDE** . . . . . N/C  
*Deadlatch with thumb turn one side.*
- **KEYLOCK 1 SIDE** (Weiser cylinder) . . . . . \$30
- **KEYLOCK 1 SIDE** (Best cylinder pull w core) . . . \$120  
*Deadlatch with thumb turn one side, keylock one side.*
- **KEYLOCK 2 SIDES** (Weiser cylinder) . . . . . \$60
- **KEYLOCK 2 SIDES** (Best cylinder pull w core) . . . \$240  
*Deadlatch with keylock two sides.*
- **NON-LOCKING FOOT-BOLT** . . . . . \$36
- **FOOT-BOLT with SPRING PIN** . . . . . \$72
- **LOCKING FOOT-BOLTS** . . . . . \$76
- **RECESSED HAT CHANNEL** . . . . . \$8 LIN.FT.  
*(Measure to top of track)*
- **CURVABLE "I" BEAM TRACK** . . . . . \$16 LIN.FT.
- **SLIDING JAMB PANEL** . . . . . \$60
- **FIRE-RETARDANCY** . . . . . add 40%  
*Panels with Class 1 fire-retardant core. Available in light oak and chalk Vinyl-Lam only. (Closet back not available with firecore)*

### LIST PRICE SCHEDULE

Use for Custom and Stock Sizes	Series 240V Vinyl-Lam	Series 240H Natural Hardwoods				
		Factory Finished				
FINISHED OPENINGS UP TO	Cherry, Maple, Gray, Birch, Natural Oak, Light Oak, Dark Oak, Teak, Mahogany, Walnut, White, Tan, Chalk, Tahiti, Rattan, Amethyst	BIRCH	OAK	CHERRY WALNUT	MAHOGANY MAPLE	
		WIDTH X HEIGHT				
Heights up to 6' 10" NO EXTRA CHARGE	2-0 x 6-8	276	450	456	588	526
	2-6 x 6-8	414	675	684	882	789
	2-8 x 6-8	414	675	684	882	789
	3-0 x 6-8	414	675	684	882	789
	4-0 x 6-8	552	900	912	1176	1052
	5-0 x 6-8	690	1125	1140	1470	1315
	6-0 x 6-8	828	1350	1368	1764	1578
	7-0 x 6-8	966	1575	1596	2058	1841
	8-0 x 6-8	1104	1800	1824	2352	2104
	9-0 x 6-8	1242	2025	2052	2646	2367
10-0 x 6-8	1380	2250	2280	2940	2630	
	Use lineal foot price for all other widths	\$138 ln. ft.	\$225 ln.ft.	\$228 ln.ft.	\$294 ln.ft.	\$263 ln.ft.
		<i>Ball-bearing wheels standard</i>				
Heights up to 8' 1" NO EXTRA CHARGE	5-0 x 8-0	835	1265	1280	1635	1470
	6-0 x 8-0	1002	1518	1536	1962	1764
	7-0 x 8-0	1169	1771	1792	2289	2058
	8-0 x 8-0	1336	2024	2048	2616	2352
	9-0 x 8-0	1503	2277	2304	2943	2646
	10-0 x 8-0	1670	2530	2560	3270	2940
	11-0 x 8-0	1837	2783	2816	3597	3234
	12-0 x 8-0	2004	3036	3072	3924	3528
	13-0 x 8-0	2171	3289	3328	4251	3822
		Use lineal foot price for all other widths	\$167 ln.ft.	\$253 ln.ft.	\$256 ln.ft.	\$327 ln.ft.
		<i>Ball-bearing wheels standard</i>				
Heights up to 10' 1" NO EXTRA CHARGE	10-0 x 10-0	2060	3270	3230	4280	4000
	11-0 x 10-0	2266	3597	3553	4708	4400
	12-0 x 10-0	2472	3924	3876	5136	4800
	13-0 x 10-0	2678	4251	4199	5564	5200
	14-0 x 10-0	2884	4578	4522	5992	5600
	15-0 x 10-0	3090	4905	4845	6420	6000
		Use lineal foot price for all other widths	\$206 ln.ft.	\$327 ln.ft.	\$323 ln.ft.	\$428 ln.ft.
		<i>Ball-bearing wheels standard</i>				
Heights up to 12' 1" NO EXTRA CHARGE	12-0 x 12-0	3228				
	13-0 x 12-0	3497				
	14-0 x 12-0	3766				
	15-0 x 12-0	4035				
		Use lineal foot price for all other widths	\$269 ln.ft.			
		<i>Ball-bearing wheels standard</i>				

**NOTE!**  
**HARDWOODS NOT AVAILABLE IN HEIGHTS OVER 10' 1".**

PRICE TO NEXT FULL FOOT WIDTH AND HEIGHT

# VISIFOLD

## Series 440/540

### Acrylic Panel Dividers

**\*\* FREIGHT \*\***  
**\*\* PREPAID \*\***

#### SERIES 440/540 SPECIFICATIONS

#### LIST PRICE SCHEDULE – All prices per Lineal Foot to the Next Full Foot

##### Aluminum Panel Frame Channels:

Clear finish*	440C	540C
White finish*	440W	540W
Bronze finish**	440B	540B
Sand finish**	440S	540S

\* Supplied with clear hinging and track

\*\* Supplied with bronze hinging and track

**Panels:** 4-1/4" wide.

**Acrylic Panels:** 1/8" thick transparent clear or bronze.

##### Panel Connectors:

Series 440 — Extruded flexible vinyl.

Series 540 — Rigid vinyl hinge profile over steel rod.

**Wheels:** Ball-bearing nylon wheels on steel axles.

##### Latch:

Series 440 — Deadlatch with thumb turn two sides.

Series 540 — Deadlatch with keylock two sides.

**Widths:** No limitations.

**Heights:** Up to 10'1".

**Stacking Space:** 1-1/4" per foot plus 2-3/4" for lead post.

#### Clear Acrylic Panels Bronze Acrylic Panels Vinyl Lam Panels

	To 8'1" Height	To 10'1" Height
Series 440	\$296	\$418
Series 540	\$362	\$513

Prices shown are per lineal foot.

#### HARDWOODS BY QUOTE

#### COMBINATION DOORS:

Series 240 may be combined with either series 440 or 640. To price combinations, use the applicable price list for each portion of the door. A diagram must be supplied noting location of each series.

#### GOLD FINISH OPTION:

Series 440 and 540 may be ordered with steel hinge hardware, aluminum components and vinyl extrusions finished in a gold color.  
Add 20%.

#### SERIES 440/640 OPTIONS

Use Series 240 Option Prices  
(see Page 5)

#### SERIES 540/740 OPTIONS

- HEIGHTS 4' AND LESS . . . . . less 20%  
*Use 8-0 height price*
- MADE AS PAIRS . . . . . \$40
- DOUBLE-END LEAD POST . . . . . \$110  
*Includes Keylock 2 sides*
- INTERMEDIATE ROLLING POST . . . . . \$60  
*(For sectioning extra wide store enclosures and/or providing a surface for attaching security bolt)*
- KEYLOCK 2 SIDES (Weiser cylinder) . . . . . Std
- KEYLOCK 2 SIDES (Best cylinder pull w core) \$180  
*Deadlatch with keylock two sides*
- PULL ROD . . . . . \$30
- KEYED 1 SIDE SINGLE 9" BOLT WITH WEISER CYLINDER . . . . . \$76  
*Special Note: Offered without cylinders if they are to be supplied by others.*
- KEYED 1 SIDE DOUBLE BOLT (floor to ceiling) WITH WEISER CYLINDER . . . . . \$152
- NON-LOCKING FOOT BOLT . . . . . \$36
- FOOT BOLT with spring pin . . . . . \$72
- LOCKING DUST PROOF STRIKE . . . . . \$36  
*(Normally inserted in floor to receive security bolt)*
- CURVABLE "T" BEAM TRACK . . . \$16 LIN.FT.
- SLIDING JAMB PANEL . . . . . \$100

# ALUMIFOLD

## Series 640/740

### Aluminum Panel Dividers

#### SERIES 640/740 SPECIFICATIONS

#### LIST PRICE SCHEDULE – All prices per Lineal Foot to the Next Full Foot

##### Panel Construction:

4-1/4" wide aluminum panels available in solid or perforated style. Frame channel is integral part of panel.

##### Panel Connectors:

Series 640 — Extruded flexible vinyl.

Series 740 — Rigid vinyl hinge profile over steel rod.

**Wheels:** Ball-bearing nylon wheels on steel axles.

##### Latch:

Series 640 — Deadlatch with thumb turn two sides.

Series 740 — Deadlatch with keylock two sides.

**Widths:** No limitations.

**Heights:** Up to 10'1".

**Stacking Space:** 1-1/4" per foot plus 2-3/4" for lead post.

#### Clear Bronze Gold\* Clear Only

	To 8'1" Height	To 10'1" Height
Series 640		
Solid	\$315	\$416
Perforated	\$372	\$503
Series 740		
Solid	\$368	\$479
Perforated	\$424	\$568

Prices shown are per lineal foot.

\*ADD 20% FOR GOLD

# SOUND RATED Series 2100

ACOUSTICAL RATING OF FSTC 21

Field Sound Transmission Class (FSTC): 21  
Test performed by Bruck, Richards & Chaudiere, Inc. ASTM designation E336-77.

## SERIES 2100 SPECIFICATIONS

**Panels:** 4-1/4" wide.

**Factory Finished Hardwoods:** For visual warmth, hardwood veneers laminated to MDF board (1/4" net) with non-tinted finish.

**Vinyl-Lam:** Wood grains, white, tan, gray or 2-tone textured vinyl laminated to MDF board (1/4" net).

**Stacking Space:** 1-1/4" per foot plus 2-3/4" for lead post.

**Molding:** Supplied as standard.

**Width:** No limitation.

**Heights:** Up to 12'1" on vinyl and 10'1" on hardwood.

**Vinyl Panel Connectors:** Supplied as standard – **White** with White, Chalk, and Amethyst.

**Sand** with Hardwoods: Oak, Birch, Maple; and Vynyls: Natural Oak, Birch, Tan, Tahiti, Rattan, Maple.

**Gray** with Gray Vinyl.

**Brown** with all other body panels.

**Wheels:** Ball-bearing nylon wheels on steel axles.

**Latch:** Deadlatch with thumb turn two sides.

**Note:** Not available with curved track or recessed track channel.

## SERIES 2100 OPTIONS

- CUSTOM SIZES **No additional charge**
- HEIGHTS 4' AND LESS . . . . . less 20%  
*Use 8-0 height price*
- MADE AS PAIRS . . . . . \$40
- SPECIAL PAINT & STAIN . . . . . \$40 LIN.FT.  
*NOTE: For custom paint finish, use (\$100 min.) wood-grain vinyl base price (MDF board, used for paint finish). For stain finish use wood-species base price. See front cover for details.*
- CUSTOM DECORATIVE LAMINATE DOORS  
*Please contact office for quotation.*
- KEYLOCK 1 SIDE (Weiser cylinder) . . . . . \$30
- KEYLOCK 1 SIDE (Best cylinder pull w core) . \$120  
*Deadlatch with thumb turn one side, keylock one side.*
- KEYLOCK 2 SIDES (Weiser cylinder) . . . . . \$60
- KEYLOCK 2 SIDES (Best cylinder pull w core) \$240  
*Deadlatch with keylock two sides.*
- NON-LOCKING FOOT BOLT . . . . . \$36
- DOUBLE-END LEAD POST . . . . . \$72
- PULL ROD . . . . . \$30
- INTERMEDIATE ROLLING POST (Metal) . . . . . \$60  
*For sectioning extra wide Room Dividers, and/or provide a surface for attaching foot bolt. (See detail Page 4.)*
- SLIDING JAMB PANEL . . . . . \$100
- FIRE-RETARDANCY . . . . . add 40%  
*Panels with Class 1 fire-retardant core. Available in light oak and chalk Vinyl-Lam only.*

## LIST PRICE SCHEDULE – All prices per Lineal Foot to the Next Full Foot

Use for Custom and Stock Sizes	Series 2100V Vinyl-Lam	Series 2100H Natural Hardwoods			
		Factory Finished			
FINISHED OPENINGS UP TO	Cherry, Maple, Gray, Birch, Natural Oak, Light Oak, Dark Oak, Teak, Mahogany, Walnut, White, Tan, Chalk, Tahiti, Rattan, Amethyst	BIRCH	OAK	CHERRY WALNUT	MAHOGANY MAPLE
HEIGHT					
Prices shown are per lineal foot	8' 1" \$219	\$322	\$325	\$396	\$364
	10' 1" \$259	\$399	\$397	\$502	\$473
	12' 1" \$342	Hardwoods not available in heights over 10' 1"			

# SOUND RATED Series 3300

ACOUSTICAL RATING OF FSTC 33

Field Sound Transmission Class (FSTC): 33  
Test performed by Bruck, Richards & Chaudiere, Inc. ASTM designation E336-90.

## SERIES 3300 SPECIFICATIONS

**Factory Finished Hardwoods:** For visual warmth, hardwood veneers laminated to MDF board (1/4" net) with non-tinted finish.

**Vinyl-Lam:** Wood grains, white, tan, gray or 2-tone textured vinyl laminated to MDF board (1/4" net).

**Width:** Individual section max. 15', use intermediate post for wider openings

**Heights:** Up to 12'1" on vinyl and 10'1" on hardwood.

**Latch:** Deadlatch with thumb turn two sides.

**Wheels:** 1-1/8" ball-bearing with steel axles.

**Vinyl Panel Connectors:** Supplied as standard – **White** with White, Chalk, and Amethyst.

**Sand** with Hardwoods: Oak, Birch, Maple; and Vynyls: Natural Oak, Birch, Tan, Tahiti, Rattan, Maple.

**Gray** with Gray Vinyl.

**Brown** with all other body panels.

**Track:** Clear aluminum with white wood moulding.

**Stacking Space:** 2" per foot plus 4-1/2" for lead post, 12-1/4" side to side.

**Note:** 3300 Series not available unfinished or with curved track.

## \*\* FREIGHT PREPAID \*\*

## SERIES 3300 OPTIONS

- CUSTOM SIZES **No additional charge**
- MADE AS PAIRS . . . . . \$100
- SPECIAL PAINT & STAIN . . . . . \$60 LIN.FT.  
*NOTE: For custom paint finish, use (\$100 min.) wood-grain vinyl base price (MDF board, used for paint finish). For stain finish use wood-species base price. See front cover for details.*
- CUSTOM DECORATIVE LAMINATE DOORS  
*Please contact office for quotation.*
- KEYLOCK 1 SIDE (Weiser cylinder) . . . . . \$30
- KEYLOCK 1 SIDE (Best cylinder pull w core) . \$120  
*Deadlatch with thumb turn one side, keylock one side.*
- KEYLOCK 2 SIDES (Weiser cylinder) . . . . . \$60
- KEYLOCK 2 SIDES (Best cylinder pull w core) \$240  
*Deadlatch with keylock two sides*
- NON-LOCKING FOOT BOLT . . . . . \$36
- PULL ROD . . . . . \$30
- 2 PIECE ALUMINUM CEILING GUARD AND TRACK (priced per lineal foot) . . . . \$20
- SLIDING JAMB . . . . . \$150
- DOUBLE-END LEAD POST . . . . . \$136
- INTERMEDIATE ROLLING POST . . . . . \$100  
*For sectioning extra wide Room Dividers, providing a surface for attaching foot bolt*
- FIRE-RETARDANCY . . . . . add 30%  
*Panels with Class 1 fire-retardant core. Available in light oak and chalk vinyl-lam only.*

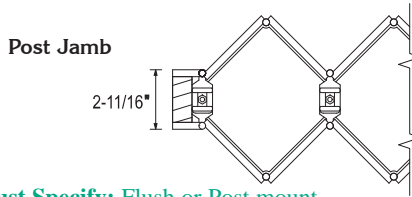
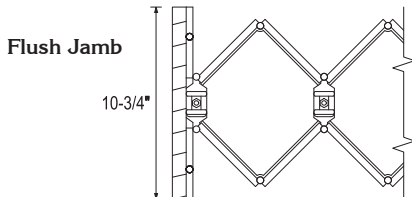

**Must Specify:** Flush or Post mount.

## LIST PRICE SCHEDULE – All Prices per Lineal Foot to the Next Full Foot

Use for Custom and Stock Sizes	Series 3300V Vinyl-Lam	Series 3300H Natural Hardwoods			
		Factory Finished			
FINISHED OPENINGS UP TO	Cherry, Maple, Gray, Birch, Natural Oak, Light Oak, Dark Oak, Teak, Mahogany, Walnut, White, Tan, Chalk, Tahiti, Rattan, Amethyst	BIRCH	OAK	CHERRY WALNUT	MAHOGANY MAPLE
HEIGHT					
Prices shown are per lineal foot	8' 1" \$513	\$715	\$675	\$845	\$785
	10' 1" \$598	\$865	\$850	\$940	\$975
	12' 1" \$678	Hardwoods not available in heights over 10' 1"			

# Woodfold Creative Decorative Options

MADE TO FIT YOUR OPENING SIZES

CONTINUOUS PIN-HINGE HARDWARE TOP  
AND BOTTOM, HEAVY-DUTY TRACK

## CUSTOM DECORATIVE LAMINATE PANELS

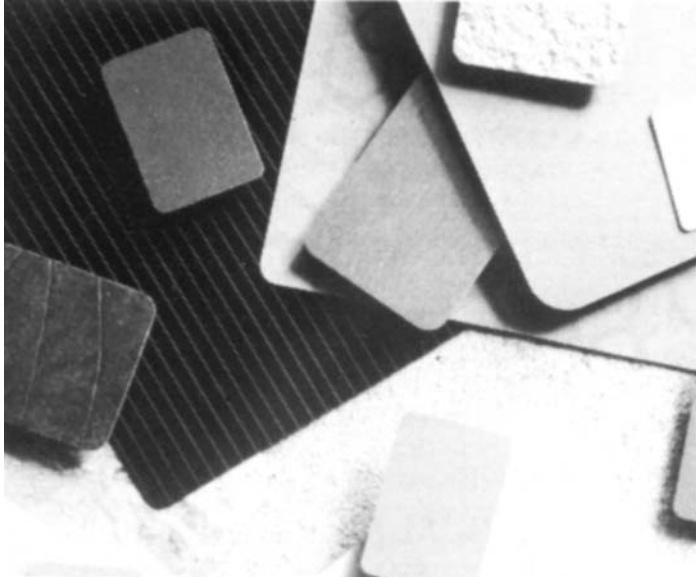

### *A Special Suggestion:*

When **solid color** laminates are specified, we suggest providing an alternate quotation using our easy-clean durable custom-paint finish.

### *A Woodfold Custom Service:*

Applying specified decorative laminates to door panels. For quotation, please advise pattern number and manufacturer such as:



NEVAMAR®  
DECORATIVE LAMINATES

WILSONART®  
BRAND DECORATIVE LAMINATE

Pionite®  
Decorative Laminates

## DISPLAY and SAMPLE KITS

Customized Samples are also available



VINYL SWATCH  
CARD - \$2.50



HARDWOOD SWATCH  
CARD - \$2.50



COLOR CHIP SET - \$8



SERIES 140 - \$40



SERIES 220 - \$40



SERIES 440 - \$40



SERIES 540 - \$40



SERIES 2100 - \$40

**\*\* FREIGHT \*\***  
**\*\* PREPAID \*\***



FD-4  
WOODFOLD DISPLAY  
\$250



SERIES 240 - \$100



SERIES 640/740 - \$100



SERIES 3300 - \$150

### WOODFOLD MFG., INC.

PO Box 346  
Forest Grove, Oregon 97116  
Phone: (503) 357-7181  
<http://www.woodfold.com>

FAX: (503) 357-7185

Distributed by: