



Accordion Doors / Zone 2

Woodfold Accordion Door Guide
for Commercial and Residential Installations
Detailed Architectural Shop Drawings Available

Suggested List Prices / Freight Prepaid
All Continental States (except California, Oregon & Washington)

Effective JAN. 1, 2016

Customer Service: 503.357.7181
Email: woodfold@woodfold.com

| Standard and Optional Features | Series: | 140 | 220 | 240 | 440 | 540 | 640 | 740 | 2100 | 3300 |
|--|---------|-----|-----|-----|-----|-----|-----|-----|------|------|
| Continuous Pin-Hinge Hardware System, Top and Bottom | | STD | STD | STD | STD | STD | STD | STD | STD | STD |
| Full-Length Sweptwing Handle with Magnet | | STD | STD | — | — | — | — | — | — | — |
| Aluminum Lead Post | | — | — | STD | STD | STD | STD | STD | STD | STD |
| Flexible Vinyl Panel Connector Inserted Directly into Panels | | STD | STD | STD | — | — | — | — | STD | STD |
| Flexible Vinyl Panel Connector Inserted into Aluminum Side Channel | | — | — | — | STD | — | — | — | — | — |
| Flexible Vinyl Panel Connector Inserted Solid Aluminum Panels | | — | — | — | — | — | STD | — | — | — |
| Rigid Vinyl Panel Connector Inserted Into Aluminum Side Channel | | — | — | — | — | STD | — | — | — | — |
| Rigid Vinyl Panel Connector Inserted Into Solid Aluminum Panels | | — | — | — | — | — | — | STD | — | — |
| Nylon Wheel on Lexan Axle | | STD | STD | — | — | — | — | — | — | — |
| Nylon Wheel with Ball Bearings on Steel Axle | | OPT | OPT | STD | STD | STD | STD | STD | STD | STD |
| Aluminum Track | | STD | STD | STD | STD | STD | STD | STD | STD | STD |
| Recessed Track Channel | | OPT | OPT | OPT | OPT | OPT | OPT | OPT | — | OPT |
| Curvable Track | | — | — | OPT | OPT | OPT | OPT | OPT | — | — |
| Magnetic Catch and Strike Plate | | STD | STD | OPT | OPT | OPT | OPT | OPT | OPT | OPT |
| Deadlatch with Thumb Turn Two Sides | | — | — | STD | STD | OPT | STD | OPT | STD | STD |
| Keylock Two Side | | — | — | OPT | OPT | STD | OPT | STD | OPT | OPT |
| May Be Paired | | — | — | OPT | OPT | OPT | OPT | OPT | OPT | OPT |
| Sliding Jamb Option | | — | — | OPT | OPT | OPT | OPT | OPT | OPT | OPT |
| Class 1 Fire Retardant Panels (Light Oak and Chalk Vinyl-Lam Only) | | — | OPT | OPT | OPT | OPT | — | — | OPT | OPT |

Measuring Width and Height

List finished opening sizes. (A) Width: Finished wall-to-wall (or jamb) in feet and inches, e.g. 10'-5" x 7'-10"; (B) Height: From surface where track attaches to finished floor or top of carpet. **See Page 4—drawings show how to measure height for each type of track.**

NOTE: For those areas where the floor is uneven (e.g. concrete floors) please take 3 or 4 height measurements along the floor. Use the shortest measurement as the finished opening height except 2100 or 3300.

**Woodfold
order
forms
available**

Prepaid Freight Program All prices shown in this price list include freight for Zone 2—all continental states except California, Oregon & Washington.

Production Schedule: All Series with factory standard finishes, 2 weeks (up to 250 lineal feet; over 250 lineal feet, subject to manufacturers schedule at time of order). All doors with special finish, after signed approval acknowledgment received, 3 weeks.

Rush service: Please contact office for details.

In-transit time: Please allow a 7 to 10 day normal in-transit time for delivery.

| Hanging door weights (lbs. per lineal foot): Contact Customer Service for shipping weight | Height | Series 140, 220, 240, 2100 | Series 440, 540, 640, 740 | Series 3300 |
|--|--------|----------------------------|---------------------------|-------------|
| | 6-8 | 10 | — | — |
| 8-0 | 12 | 13 | 26 | |
| 10-0 | 15 | 16 | 32 | |
| 12-0 | 18 | N/A | 38 | |

Shipments to non-commercial addresses: Additional charges apply for non-commercial delivery and pre-delivery notification. Contact office for questions.

Special note: In case of freight damage documented with signed bill of lading, please contact our office. Woodfold will process freight claim.

Custom sizes are our specialty

Custom Order Information

All Woodfold doors are custom made. We allow 9/16" clearance for doors over 4' high, 5/16" for doors 4' and less. Beware of variations in floor and/or ceiling surfaces of more than 3/4". Please contact us for more information.

Special finishes procedure: With your order please send stained wood sample or paint chip to be matched by Woodfold. Upon receiving this sample we will return a factory color-matched sample along with an acknowledgment copy. Acknowledgment is to be returned with your signature approving the color match. By using the special finish procedure to color match to your customer requirements, the special finish cost will be less than preparing an unfinished door for finishing at the job site.

Unfinished doors are not guaranteed

Series 3300 is not available unfinished

Woodfold finishing processes are environmentally safe

Residential Series 140

Closet Folding Doors—Faced One Side Only

- Order must specify left- or right-hand stack.
- Not available as pairs
- When pairs are required, use Series 240.

Freight Prepaid 

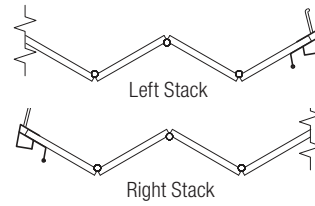

The Accordion Door That:

- Is FULLY Guaranteed
- STACKS in Minimum Space
- STAYS PUT in Open and Closed Position
- Has Exclusive Pin-Hinge Hardware Top and Bottom for Added Strength

Series 140 Specifications

Panels: 4'-1/4" wide.

Factory finished hardwoods:

For visual warmth, hardwood veneers laminated to MDF board (1/4" net) with non-tinted finish. Good one side.

Vinyl-Lam: Wood grains, white, tan, gray, or 2-tone textured vinyl laminated to MDF board (1/4" net), faced one side only.

Catch: Magnet with strike plate.

Widths: Up to 8'. (note: For closet enclosures more than 8' wide, use Series 240 with closet-back option, page 5).

Heights: Up to 8'-1".

Wheels: Nylon wheels on Lexan axles.

Vinyl panel connectors:

Supplied as standard—

White with White, Chalk, and Amethyst.

Sand with Hardwoods: Oak, Birch, Maple, Alder; and Vinyls: Natural Oak, Birch, Tan, Tahiti, Rattan, Maple.

Gray with Gray Vinyl.

Brown with all other body panels.

Stacking space: 1-1/4" per foot plus 7/8" for sweptwing handle.

Note: Not available with curved track.



List Price Schedule (Price to next full foot width and height)

| Use for Custom and Stock Sizes | | Series 140V Vinyl-Lam | Series 140H Natural Hardwoods | | | |
|---|-----------|---|-------------------------------|---------------|-----------------------|------|
| Finished Openings up to | | Birch, Cherry, Maple, Walnut, Natural Oak, Light Oak, Dark Oak, Mahogany, White, Chalk, Tan, Gray, Black,* Teak, Tahiti, Rattan, Amethyst | Factory Finished | | | |
| Width x Height | Birch | | Oak | Cherry Walnut | Alder* Mahogany Maple | |
| Heights up to 6'-10" No Extra Charge | 2-0 x 6-8 | 250 | 430 | 436 | 562 | 502 |
| | 3-0 x 6-8 | 375 | 645 | 654 | 843 | 753 |
| | 4-0 x 6-8 | 500 | 860 | 872 | 1124 | 1004 |
| | 5-0 x 6-8 | 625 | 1075 | 1090 | 1405 | 1255 |
| | 6-0 x 6-8 | 750 | 1290 | 1308 | 1686 | 1506 |
| | 7-0 x 6-8 | 875 | 1505 | 1526 | 1967 | 1757 |
| Heights up to 8'-1" No Extra Charge | 8-0 x 6-8 | 1000 | 1720 | 1744 | 2248 | 2008 |
| | 2-0 x 8-0 | 278 | 480 | 486 | 618 | 556 |
| | 3-0 x 8-0 | 417 | 720 | 729 | 927 | 834 |
| | 4-0 x 8-0 | 556 | 960 | 972 | 1236 | 1112 |
| | 5-0 x 8-0 | 695 | 1200 | 1215 | 1545 | 1390 |
| | 6-0 x 8-0 | 834 | 1440 | 1458 | 1854 | 1668 |
| 7-0 x 8-0 | 973 | 1680 | 1701 | 2163 | 1946 | |
| 8-0 x 8-0 | 1112 | 1920 | 1944 | 2472 | 2224 | |

Maximum size for Series 140: 8-0 x 8-1 *Black and Alder available only up to 8-1

Series 140 Options

- **Custom-size doors no additional charge**
Use price for next larger width and height shown; see Page 1 for providing custom-size details.
- **Heights 4' and less** less 20%
Use 8-0 height price.
- **Double end** \$20
Single door with sweptwing handle both ends.
- **Not available with keylocks or privacy latches (for these options, use Series 240 with closet back).**
- **Special paint and stain** \$40 lin. ft.
\$100 minimum. Note: For custom paint finish, use wood grain vinyl price base (MDF board with paper overlay used for paint finish). For stain finish, use wood-species base price. See front cover for details.
- **Fire-retardancy** N/A
Panels with fire-retardant core not available in Series 140. Please refer to options for Series 220 and 240.

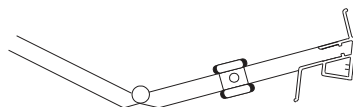

Series 140 with full-length sweptwing handle with integral magnet and steel hardware hinge (top view). Note: The first body panel acts as lead panel.

Residential Series 220

Room Dividers and Passageway Doors

- Not available as pairs.
- When pairs are required, use Series 240.
- Built left-hand stack unless otherwise specified.

Freight Prepaid 

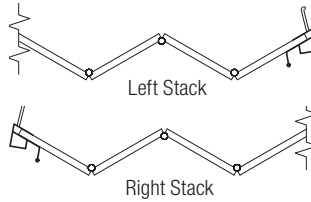

How To Order (Custom Sizes Our Specialty)

- 1) WIDTH: Finished wall-to-wall (or jamb) in feet and inches.
- 2) HEIGHT: Surface where track attaches to finished floor or top of carpet in feet and inches.
- 3) SERIES: List number of series to be ordered.
- 4) PANEL: List wood species or vinyl-lam color.
- 5) OPTIONS: List options if required.

Series 220 Specifications

Panels: 4-1/4" wide.

Factory finished hardwoods:

For visual warmth, hardwood veneers laminated to MDF board (1/4" net) with non-tinted finish.

Vinyl-Lam: Wood grains, white, tan, gray, or 2-tone textured vinyl laminated to MDF board (1/4" net).

Catch: Magnet with strike plate

Widths: Up to 8'. (Note: For room dividers more than 8' wide, use Series 240, Page 5).

Heights: Up to 8'-1".

Wheels: Nylon wheels on Lexan axles.

Vinyl panel connectors:

Supplied as standard—

White with White, Chalk, and Amethyst.

Sand with Hardwoods: Oak, Birch, Maple, Alder; and Vinyls: Natural Oak, Birch, Tan, Tahiti, Rattan, Maple.

Gray with Gray Vinyl.

Brown with all other body panels.

Stacking space: 1-1/4" per foot plus 7/8" for sweptwing handle.

Note: Not available with curved track.



List Price Schedule (Price to next full foot width and height)

| Use for Custom and Stock Sizes | Series 220V Vinyl-Lam | Series 220H Natural Hardwoods | | | | |
|---|---|-------------------------------|------|---------------|-----------------------|------|
| Finished Openings up to | Birch, Cherry, Maple, Walnut, Natural Oak, Light Oak, Dark Oak, Mahogany, White, Chalk, Tan, Gray, Black*, Teak, Tahiti, Rattan, Amethyst | Factory Finished | | | | |
| Width x Height | | Birch | Oak | Cherry Walnut | Alder* Mahogany Maple | |
| Heights up to 6'-10" No Extra Charge | 2-0 x 6-8 | 260 | 438 | 442 | 574 | 516 |
| | 3-0 x 6-8 | 390 | 657 | 663 | 861 | 774 |
| | 4-0 x 6-8 | 520 | 876 | 884 | 1148 | 1032 |
| | 5-0 x 6-8 | 650 | 1095 | 1105 | 1435 | 1290 |
| | 6-0 x 6-8 | 780 | 1314 | 1326 | 1722 | 1548 |
| | 7-0 x 6-8 | 910 | 1533 | 1547 | 2009 | 1806 |
| Heights up to 8'-1" No Extra Charge | 2-0 x 8-0 | 288 | 488 | 494 | 634 | 566 |
| | 3-0 x 8-0 | 432 | 732 | 741 | 951 | 849 |
| | 4-0 x 8-0 | 576 | 976 | 988 | 1268 | 1132 |
| | 5-0 x 8-0 | 720 | 1220 | 1235 | 1585 | 1415 |
| | 6-0 x 8-0 | 864 | 1464 | 1482 | 1902 | 1698 |
| | 7-0 x 8-0 | 1008 | 1708 | 1729 | 2219 | 1981 |
| 8-0 x 8-0 | 1152 | 1952 | 1976 | 2536 | 2264 | |

Maximum size for Series 220: 8-0 x 8-1 *Black and Alder available only up to 8-1

Series 220 Options

- **Custom-size doors no additional charge**
Use price for next larger width and height shown; see Page 1 for providing custom-size details.
- **Heights 4' and less** less 20%
Use 8-0 height price.
- **Double end** \$20
Single door with sweptwing handle both ends.
- **Not available with keylocks or privacy latches (for these options, use Series 240).**
- **Special paint and stain** \$40 lin. ft. \$100 minimum. Note: For custom paint finish, use wood grain vinyl price base (MDF board with paper overlay used for paint finish). For stain finish, use wood-species base price. See front cover for details.
- **Fire-retardancy** add 40%
Panels with Class 1 fire-retardant core. Available in light oak and chalk vinyl-lam only.

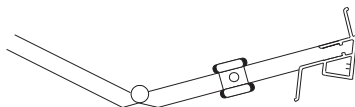

Series 220 with full-length sweptwing handle with integral magnet and steel hardware hinge (top view). Note: The first body panel acts as lead panel.

Construction Details Series 240, 440, 540, 640, 740

Standard Surface Track

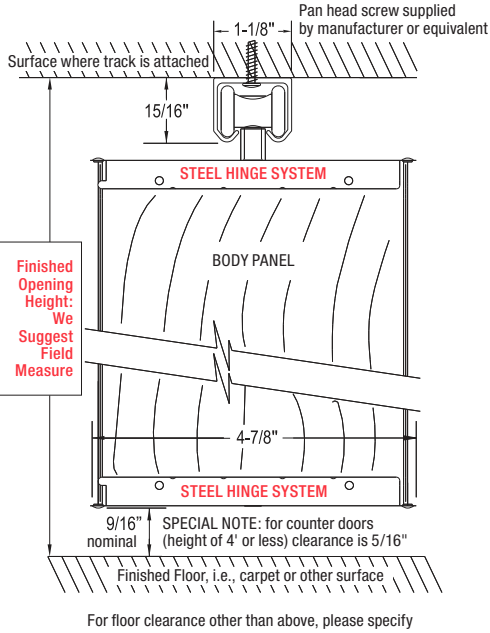

Stack Dimensions

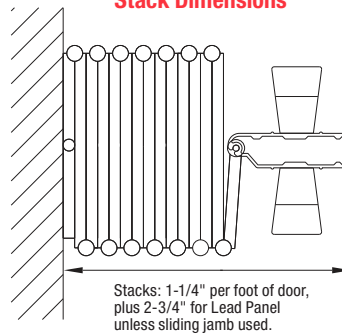

Lead Post

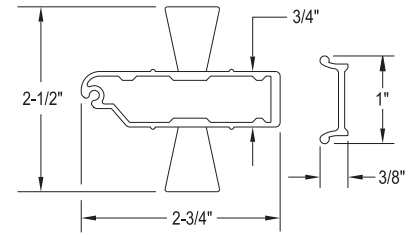

Mounting Panel

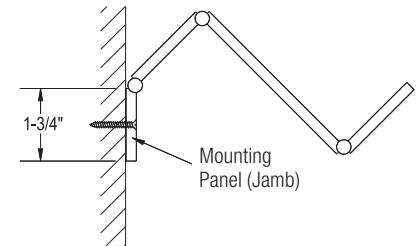

Jamb panels may orient into or out of room based on number of panels in door. Applies to all series except 3300.

Door Types

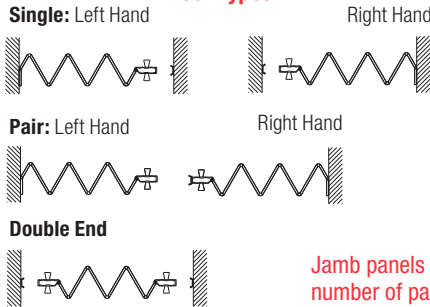

Option Details Series 240, 440, 540, 640, 740

Woodfold Customer Service:

503.357.7181 / woodfold@woodfold.com

Locking Hardware

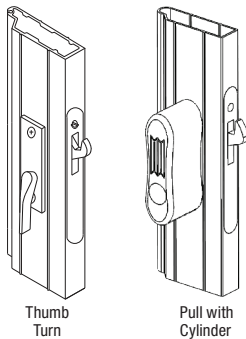

- **Deadlatch**
Deadlatch with thumb turn two sides
 - **Keylock 1 Side**
Deadlatch with thumb turn one side, keylock one side
 - **Keylock 2 Sides**
Deadlatch with keylock 2 sides
- Custom Keying Information**
Woodfold furnishes Weiser, Schlage, and a construction best cylinder.

Intermediate Rolling Post

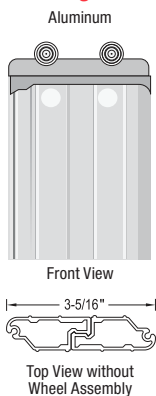

Each half of the post applied to section of Room Divider at plant. Fastening of sections at job site with screws and posts supplied.

Recessed Track

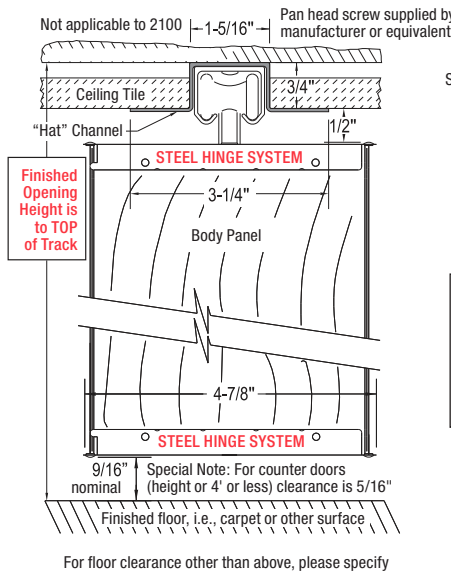

Curvable Track

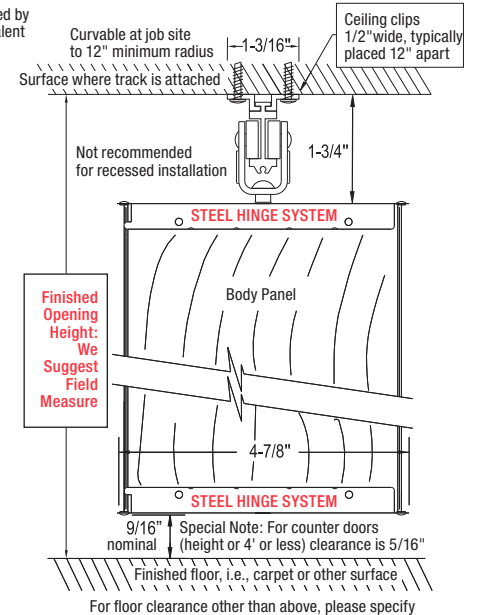

Sliding Jamb Option

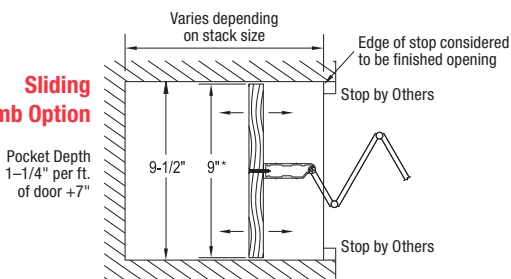

* May be cut to a minimum of 6-1/2" in the field

Multiple Meeting Options

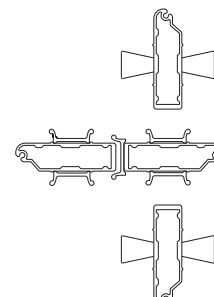

Up to four way use of jamb mold in place of handle on sides of lead panel

Primary lead post with auxiliary jamb moldings

Commercial Series 240

Room Dividers and Passageway Doors

Freight
Prepaid 

Series 240 Specifications

Panels: 4-1/4" wide.

Factory finished hardwoods:

For visual warmth, hardwood veneers laminated to MDF board (1/4" net) with non-tinted finish.

Vinyl-Lam: Wood grains, white, tan, gray, or 2-tone textured vinyl laminated to MDF board (1/4" net).

Lead Post: 3/4" x 2-3/4" aluminum with ball-bearing rollers.

Latch: Deadlatch with thumb turn two sides.

Widths: No limitation.

Heights: Up to 12'-1" on vinyl and 10'-1" on hardwood.

Vinyl panel connectors:

Supplied as standard—

White with White, Chalk, and Amethyst.

Sand with Hardwoods: Oak, Birch, Maple, Alder; and Vinyls: Natural Oak, Birch, Tan, Tahiti, Rattan, Maple.

Gray with Gray Vinyl.

Brown with all other body panels.

Wheels: Ball-bearing nylon wheels on steel axles.

Stacking space: 1-1/4" per foot plus 2-3/4" for lead post.

How To Order (Custom Sizes Our Specialty)

- 1) WIDTH: Finished wall-to-wall (or jamb) in feet and inches.
- 2) HEIGHT: Surface where track attaches to finished floor or top of carpet in feet and inches.
- 3) SERIES: List number of series to be ordered.
- 4) PANEL: List wood species or vinyl-lam color.
- 5) OPTIONS: List options if required.

Series 240 Options

- **Custom-sizes** no additional charge
- **Heights 4' and less** less 20%
Use 8-0 height price.
- **Made as pairs** \$40
- **Double end lead post** \$40
- **Intermediate rolling post** \$60
For sectioning extra-wide dividers and to provide a surface to attach foot-bolt. See Page 4.
- **Closet backs on Series 240** Less 10%
Order right or left hand. Available up to 8'1" height.
- **Unfinished doors**
Not guaranteed. Use finished door prices.
- **Special paint and stain** \$40 lin. ft.
\$100 minimum. Note: For custom paint finish, use wood grain vinyl price base (MDF board with paper overlay used for paint finish). For stain finish, use wood-species base price. See front cover for details.
- **Custom decorative laminate doors**
Contact office for quotation.
- **Magnet with strike plate** N/C
- **Thumb turn two sides** STD
Deadlatch with thumb turn two sides.
- **Thumb turn one side** N/C
Deadlatch with thumb turn one side.
- **Keylock 1 side (Weiser or Schlage cylinder)** ... \$60
- **Keylock 1 side (Best cylinder pull w core)** \$120
Deadlatch with thumb turn one side.
- **Keylock 2 sides (Weiser or Schlage cylinder)** \$120
- **Keylock 2 sides (Best cylinder pull w core)** \$240
Deadlatch with keylock two sides.
- **Non-locking foot-bolt** \$36
- **Foot-bolt with spring pull** \$72
- **Locking foot-bolts** \$76
- **Double locking foot-bolts** \$152
- **Recessed hat channel** \$8 lin. ft.
Measure to top of track.
- **Curvable "I" beam track** \$16 lin. ft.
- **Sliding jamb panel** \$60
- **Fire-retardancy** add 40%
Panels with Class 1 fire-retardant core. Available in light oak and chalk vinyl-lam only (closet back not available with firecore).

List Price Schedule (Price to next full foot width and height)

| Use for Custom and Stock Sizes | | Series 240V Vinyl-Lam | Series 240H Natural Hardwoods | | | |
|---|---|---|---|--------------|---------------|-----------------------|
| Finished Openings up to | | Birch, Cherry, Maple, Walnut, Natural Oak, Light Oak, Dark Oak, Mahogany, White, Chalk, Tan, Gray, Black*, Teak, Tahiti, Rattan, Amethyst | Factory Finished | | | |
| Width x Height | | | Birch | Oak | Cherry Walnut | Alder* Mahogany Maple |
| Heights up to 6'10" No Extra Charge | 2-0 x 6-8 | 316 | 516 | 522 | 662 | 596 |
| | 3-0 x 6-8 | 474 | 774 | 783 | 993 | 894 |
| | 4-0 x 6-8 | 632 | 1032 | 1044 | 1324 | 1192 |
| | 5-0 x 6-8 | 790 | 1290 | 1305 | 1655 | 1490 |
| | 6-0 x 6-8 | 948 | 1548 | 1566 | 1986 | 1788 |
| | 7-0 x 6-8 | 1106 | 1806 | 1827 | 2317 | 2086 |
| | 8-0 x 6-8 | 1264 | 2064 | 2088 | 2648 | 2384 |
| | 9-0 x 6-8 | 1422 | 2322 | 2349 | 2979 | 2682 |
| | 10-0 x 6-8 | 1580 | 2580 | 2610 | 3310 | 2980 |
| | Use linear foot price list for all other widths | | 158 lin. ft. | 258 lin. ft. | 261 lin. ft. | 331 lin. ft. |
| Heights up to 8'1" No Extra Charge | 5-0 x 8-0 | 955 | 1440 | 1465 | 1840 | 1665 |
| | 6-0 x 8-0 | 1146 | 1728 | 1758 | 2208 | 1998 |
| | 7-0 x 8-0 | 1337 | 2016 | 2051 | 2576 | 2331 |
| | 8-0 x 8-0 | 1528 | 2304 | 2344 | 2944 | 2664 |
| | 9-0 x 8-0 | 1719 | 2592 | 2637 | 3312 | 2997 |
| | 10-0 x 8-0 | 1910 | 2880 | 2930 | 3680 | 3330 |
| | 11-0 x 8-0 | 2101 | 3168 | 3223 | 4048 | 3663 |
| | 12-0 x 8-0 | 2292 | 3456 | 3516 | 4416 | 3996 |
| | 13-0 x 8-0 | 2483 | 3744 | 3809 | 4784 | 4329 |
| | Use linear foot price list for all other widths | | 191 lin. ft. | 288 lin. ft. | 293 lin. ft. | 368 lin. ft. |
| Heights up to 10'1" No Extra Charge | 10-0 x 10-0 | 2350 | 3710 | 3680 | 4770 | 4470 |
| | 11-0 x 10-0 | 2585 | 4081 | 4048 | 5247 | 4917 |
| | 12-0 x 10-0 | 2820 | 4452 | 4416 | 5724 | 5364 |
| | 13-0 x 10-0 | 3055 | 4823 | 4784 | 6201 | 5811 |
| | 14-0 x 10-0 | 3290 | 5194 | 5152 | 6678 | 6258 |
| | 15-0 x 10-0 | 3525 | 5565 | 5520 | 7155 | 6705 |
| Use linear foot price list for all other widths | | 235 lin. ft. | 371 lin. ft. | 368 lin. ft. | 477 lin. ft. | 447 lin. ft. |
| Heights up to 12'1" No Extra Charge | 12-0 x 12-0 | 3684 | <p>Note: Hardwoods not available in heights over 10-1</p> <p>*Black and Alder available only up to 8-1</p> | | | |
| | 13-0 x 12-0 | 3991 | | | | |
| | 14-0 x 12-0 | 4298 | | | | |
| | 15-0 x 12-0 | 4605 | | | | |
| | Use linear foot price list for all other widths | | | | | |

Visifold Series 440/540

Acrylic Panel Dividers



Series 440/540 Specifications

Aluminum panel frame channels:

| | | |
|-----------------|------|------|
| Clear finish* | 440C | 540C |
| White finish* | 440W | 540W |
| Bronze finish** | 440B | 540B |
| Sand finish** | 440S | 540S |

* Supplied with clear hinging and track.
** Supplied with bronze hinging and track.

Panels: 4-1/4" wide.

Acrylic panels:

1/8" thick transparent clear or bronze.

Panel connectors:

Series 440—Extruded flexible vinyl.
Series 540—Rigid vinyl hinge profile over steel rod.

Wheels:

Ball-bearing nylon wheels on steel axles.

Latch:

Series 440—Deadlatch with thumb turn two sides.
Series 540—Deadlatch with keylock turn two sides.

Widths: No limitations.

Heights: Up to 10'-1".

Stacking space: 1-1/4" per foot plus 2-3/4" for lead post.

List Price Schedule (Prices per lineal foot to the next full foot)

Clear Acrylic Panels - Bronze Acrylic Panels - Vinyl-Lam Panels

| | Series 440 | Series 540 | Hardwoods by quote |
|------------------|------------|------------|-----------------------|
| To 8'-1" height | 323 | 383 | |
| To 10'-1" height | 442 | 537 | |

Prices shown are per lineal foot

Alumifold Series 640/740

Aluminum Panel Dividers



Series 640/740 Specifications

Panels construction: 4-1/4" wide aluminum panels available in solid or perforated style. Frame channel is integral part of panel.

Panel connectors:

Series 640—Extruded flexible vinyl.
Series 740—Rigid vinyl hinge profile over steel rod.

Wheels:

Ball-bearing nylon wheels on steel axles.

Latch:

Series 640—Deadlatch with thumb turn two sides.
Series 740—Deadlatch with keylock turn two sides.

Widths: No limitations.

Heights: Up to 10'-1".

Stacking space: 1-1/4" per foot plus 2-3/4" for lead post.

List Price Schedule (Prices per lineal foot to the next full foot)

| | Series 640 Solid / Perforated | Series 740 Solid / Perforated |
|---|----------------------------------|----------------------------------|
| Clear, Bronze, or Gold* to 8'-1" height | 334 / 390 | 387 / 446 |
| Clear only to 10'-1" height | 435 / 527 | 503 / 597 |

*Add 20% for gold. Prices shown are per lineal foot.

Combination doors:

Series 240 may be combined with either Series 440 or 640. To price combinations, use the applicable price list for each portion of the door. A diagram must be supplied noting location of each series.

Gold finish option:

Series 440 and 540 may be ordered with steel hinge hardware, aluminum components, and vinyl extrusions finished in a gold color. Add 20%.

Series 440/640 Options

Use Series 240 Option Prices on Page 5

Series 540/740 Options

- **Heights 4' and less** less 20%
Use 8-0 height price.
- **Made as pairs** \$40
- **Double-end lead post** \$110
Includes keylock 2 sides.
- **Intermediate rolling post** \$60
For sectioning extra-wide store enclosures and/or providing a surface for attaching security bolt.
- **Keylock 2 sides** (Weiser or Schlage cylinder) . STD
- **Keylock 2 sides** (Best cylinder pull w core) ... \$180
Deadlatch with keylock two sides.
- **Pull rod** \$30
- **Locking foot bolts** \$76
- **Double locking foot-bolts** (floor to ceiling) \$152
- **Non-locking foot-bolt** \$36
- **Foot-bolt with spring pin** \$72
- **Locking dust-proof strike** \$36
Normally inserted in floor to receive security bolt,
- **Curvable "I" beam track** \$16 lin. ft.
- **Sliding jamb panel** \$100

Sound Rated Series 2100

Acoustical Rating of FSTC 21

Field Sound Transmission Class (FSTC): 21

Test performed by Bruck, Richards & Chaudiere, Inc. ASTM designation E336-77

Freight Prepaid



Series 2100 Specifications

Panels: 4-1/4" wide.

Factory finished hardwoods: For visual warmth, hardwood veneers laminated to MDF board (1/4" net) with non-tinted finish.

Vinyl-Lam: wood grains, white, tan, gray, or 2-toned textured vinyl laminated to MDF board (1/4" net).

Stacking space: 1-1/4" per foot plus 2-3/4" for lead post.

Molding: Supplied as standard.

Widths: No limitation.

Heights: Up 12'-1" on vinyl and 10'-1" on hardwood.

Vinyl panel connectors:

Supplied as standard—

White with White, Chalk, and Amethyst.

Sand with Hardwoods: Oak, Birch, Maple, Alder; and Vinyls: Natural Oak, Birch, Tan, Tahiti, Rattan, Maple.

Gray with Gray Vinyl.

Brown with all other body panels.

Wheels: Ball-bearing nylon wheels on steel axles.

Latch: Deadlatch with thumb turn two sides.

Note: Not available with curved track or recessed track channel.

List Price Schedule (Prices per lineal foot to the next full foot)

| Use for Custom and Stock Sizes | Series 2100V Vinyl-Lam | | Series 2100H Natural Hardwoods | | | |
|----------------------------------|------------------------|---|---|-----|---------------|-----------------------|
| | Height | Birch, Cherry, Maple, Walnut, Natural Oak, Light Oak, Dark Oak, Mahogany, White, Chalk, Tan, Gray, Black,* Teak, Tahiti, Rattan, Amethyst | Birch | Oak | Cherry Walnut | Alder* Mahogany Maple |
| Prices shown are per lineal foot | 8'-1" | 251 | 370 | 373 | 449 | 413 |
| | 10'-1" | 297 | 458 | 454 | 567 | 535 |
| | 12'-1" | 391 | Hardwoods not available in heights over 10'-1" *Available only in 8'-1" | | | |

Sound Rated Series 3300

Acoustical Rating of FSTC 33

Field Sound Transmission Class (FSTC): 33

Test performed by Bruck, Richards & Chaudiere, Inc. ASTM designation E336-90

Series 3300 Specifications

Factory finished hardwoods:

For visual warmth, hardwood veneers laminated to MDF board (1/4" net) with non-tinted finish.

Vinyl-Lam: wood grains, white, tan, gray, or 2-toned textured vinyl laminated to MDF board (1/4" net).

Widths: Individual section max. 15'; use intermediate post for wider openings.

Heights: Up 12'-1" on vinyl and 10'-1" on hardwood.

Latch: Deadlatch with thumb turn two sides.

Wheels:

1-1/8" ball-bearing nylon wheels on steel axles.

Vinyl panel connectors: Supplied as standard—

White with White, Chalk, and Amethyst.

Sand with Hardwoods: Oak, Birch, Maple, Alder; and Vinyls: Natural Oak, Birch, Tan, Tahiti, Rattan, Maple.

Gray with Gray Vinyl.

Brown with all other body panels.

Track: Clear aluminum with white wood moulding.

Stacking space: 2" per foot plus 4-1/2" for lead post, 12-1/4" side to side.

Note: Series 3300 not available unfinished or with curved track.

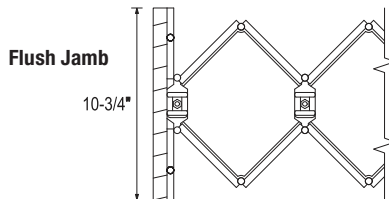

Flush Jamb

10-3/4"

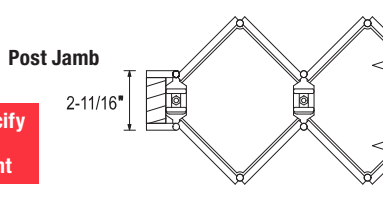

Post Jamb

2-11/16"

Must specify Flush or Post Mount

List Price Schedule (Prices per lineal foot to the next full foot)

| Use for Custom and Stock Sizes | Series 3300V Vinyl-Lam | | Series 3300H Natural Hardwoods | | | |
|----------------------------------|------------------------|---|---|-----|---------------|-----------------------|
| | Height | Birch, Cherry, Maple, Walnut, Natural Oak, Light Oak, Dark Oak, Mahogany, White, Chalk, Tan, Gray, Black,* Teak, Tahiti, Rattan, Amethyst | Birch | Oak | Cherry Walnut | Alder* Mahogany Maple |
| Prices shown are per lineal foot | 8'-1" | 594 | 828 | 782 | 979 | 908 |
| | 10'-1" | 693 | 1002 | 984 | 1089 | 1129 |
| | 12'-1" | 785 | Hardwoods not available in heights over 10'-1" *Available only in 8'-1" | | | |

Series 2100 Options

- **Custom-sizes** no additional charge
- **Heights 4' and less** less 20%
Use 8-0 height price.
- **Made as pairs** \$40
- **Special paint and stain** \$40 lin. ft.
\$100 minimum. Note: For custom paint finish, use wood-grain vinyl price base (MDF board with paper overlay used for paint finish). For stain finish, use wood-species base price. See front cover for details.
- **Custom decorative laminate doors**
Contact office for quotation.
- **Keylock 1 side** (Weiser or Schlage cylinder) \$60
- **Keylock 1 side** (Best cylinder pull w core) \$120
Deadlatch with thumb turn one side, keylock one side.
- **Keylock 2 sides** (Weiser or Schlage cylinder) ... \$120
- **Keylock 2 sides** (Best cylinder pull w core) \$240
Deadlatch with keylock two sides.
- **Non-locking foot-bolt** \$36
- **Double end lead post** \$72
- **Pull rod** \$30
- **Intermediate rolling post** (metal) \$60
For sectioning extra-wide room dividers, and/or to provide a surface for attaching foot-bolt. See detail Page 4.
- **Sliding jamb panel** \$100
- **Fire-retardancy** add 40%
Panels with Class 1 fire-retardant core. Available in light oak and chalk vinyl-lam only.

Series 3300 Options

- **Custom-sizes** no additional charge
- **Made as pairs** \$100
- **Special paint and stain** \$60 lin. ft.
\$100 minimum. Note: For custom paint finish, use wood-grain vinyl price base (MDF board with paper overlay used for paint finish). For stain finish, use wood-species base price. See front cover for details.
- **Custom decorative laminate doors**
Contact office for quotation.
- **Keylock 1 side** (Weiser or Schlage cylinder) \$60
- **Keylock 1 side** (Best cylinder pull w core) \$120
Deadlatch with thumb turn one side, keylock one side.
- **Keylock 2 sides** (Weiser or Schlage cylinder) ... \$120
- **Keylock 2 sides** (Best cylinder pull w core) \$240
Deadlatch with keylock two sides.
- **Non-locking foot-bolt** \$36
- **Pull rod** \$30
- **2-piece aluminum ceiling guard and track** (Priced per lineal foot) \$20
- **Sliding jamb** \$150
- **Double end lead post** \$136
- **Intermediate rolling post** \$100
For sectioning extra-wide room dividers, providing a surface for attaching foot-bolt.
- **Fire-retardancy** add 30%
Panels with Class 1 fire-retardant core. Available in light oak and chalk vinyl-lam only.



Woodfold Creative Decorative Options

Made to fit your opening sizes
Continuous pin-hinge hardware
top and bottom, heavy-duty track

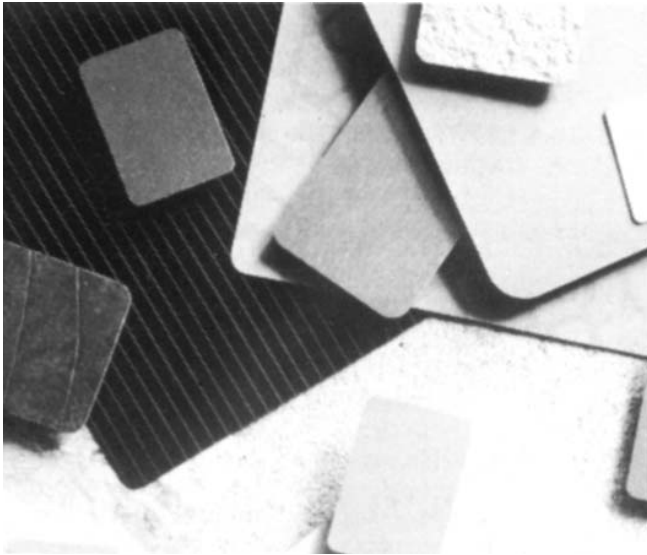

Custom Decorative Laminate Panels

A Special Suggestion: When *solid color* laminates are specified, we suggest providing an alternate quotation using our easy-clean durable custom-paint finish.

A Woodfold Custom Service: Applying specified decorative laminates to door panels. For quotation, please advise pattern number and manufacturer such as:



Display and Sample Kits—Customized Samples Are Also Available



Vinyl Swatch Card—\$2.50



Hardwood Swatch Card—\$2.50



Color Chip Set—\$8



Series 140—\$40



Series 220—\$40



Series 440—\$40



Series 540—\$40



Series 2100—\$40

**Freight
Prepaid** 



Series 240—\$100



Series 640/740—\$100



Series 3300—\$150

WOODFOLD MFG., INC.

PO Box 346
Forest Grove, Oregon 97116
P: 503.357.7181
F: 503.357.7185
woodfold@woodfold.com
woodfold.com

Distributed by: